



THE CONTEST 40CS

# 40CS



*Contest*

YACHTS

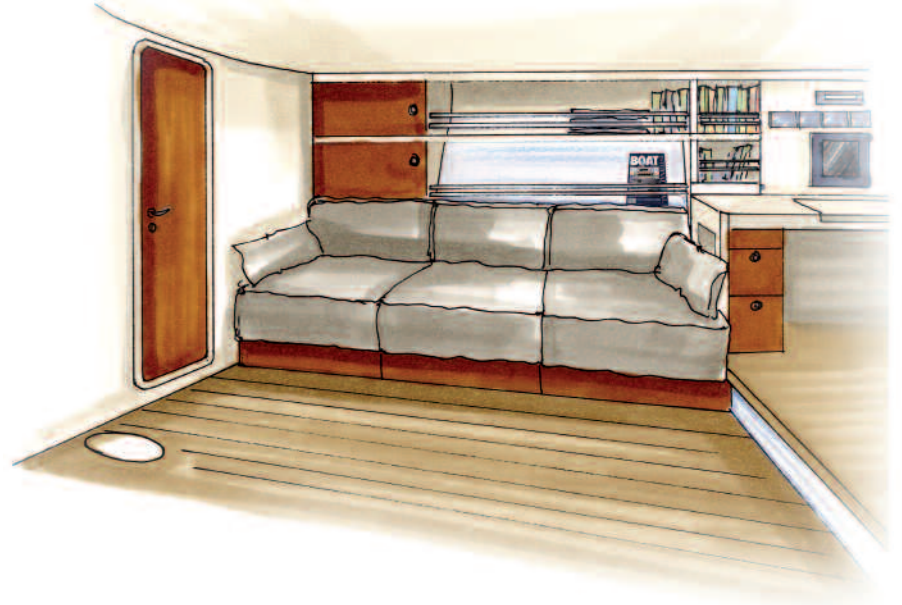
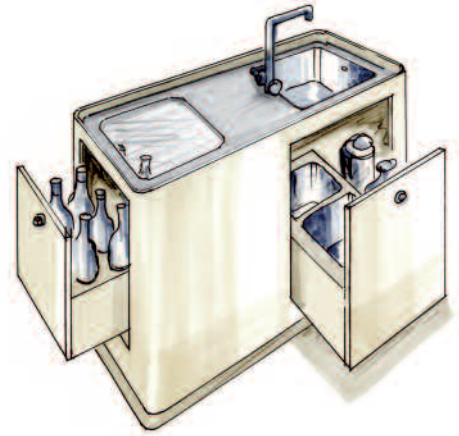
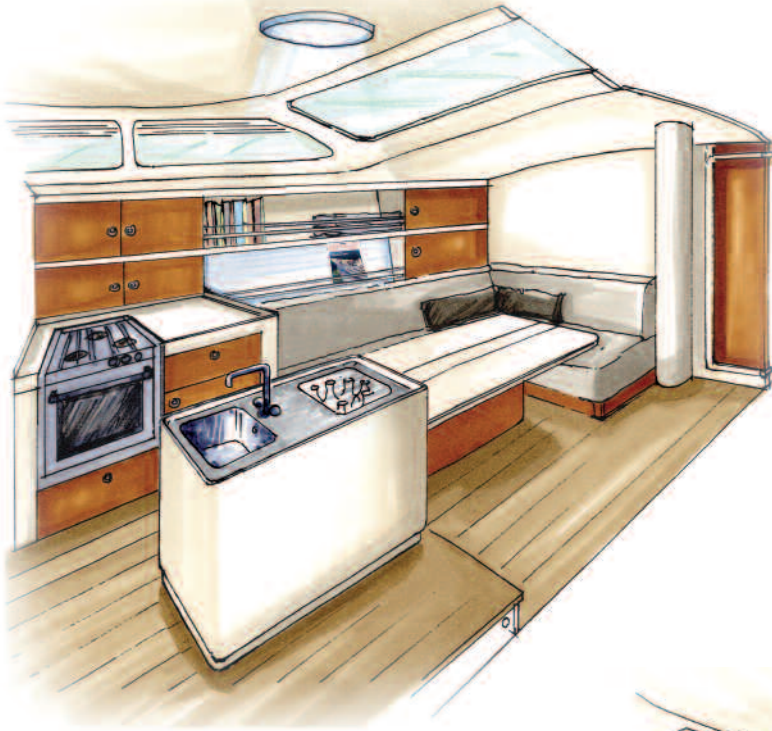

**Completely in harmony with the other Contest yachts from the CS range and yet surprisingly different... It is our pleasure to introduce the newest member of the Contest family. The Contest 40CS is the first model in the series to have an aft cockpit, enhancing her sporty looks. She also offers impressive sailing while providing the premium standard of comfort you have come to expect from a Contest. Your search for a stylish performance cruiser is at an end.**

The Contest 40CS will be popular with many types of sailors. An ingenious design means that the yacht is equally suitable for families and friends who love comfortable cruising as it is for racers who wish to take part in regattas. In other words, multipurpose sailing is at the heart of the design philosophy and the Contest 40CS incorporates the finest elements from its bigger sisters.

The appearance of the Contest 40CS hints at the excellent performance that awaits you once at the helm. And you certainly won't be disappointed as the powerful bow and advanced underwater ship slices through the water. Safe and course-steady, superior maneuverability is provided by the performance-oriented keel and rudder. The sail drive also ensures that once under way you can make the most of the enormous potential of the Contest 40CS.

Standing on the deck, it is immediately clear that the pleasures of sailing have been given full priority. The large cockpit means you and your guests have a wealth of space in which to move around. The foredeck is clean and orderly, with the reef genoa drum being stored below the deck. Thanks to the smart layout of the winches and lines, fast and effective sail trimming is assured. And it goes without saying that this performance cruiser comes standard with a fractional rig and angled spreaders.

As always on a Contest yacht, no compromises have been made when it comes to ensuring the finest below deck comfort. The interior design is by Birgit Schnaase, who has created a light and spacious atmosphere. The modern look and layout, including a cooking island, make the Contest 40CS feel fresh and inviting. You can choose between a two- or three-cabin version, with four to six large berths. Regardless of how many people you invite onboard, the Contest 40CS will always feel far more capacious than you would expect from a yacht this size.

Struggling to choose between a performance boat and a cruising yacht? The ideal solution is now at hand... The Contest 40 CS offers you the both worlds in one.



# A/B INTERIOR LAYOUT



INTERIOR A

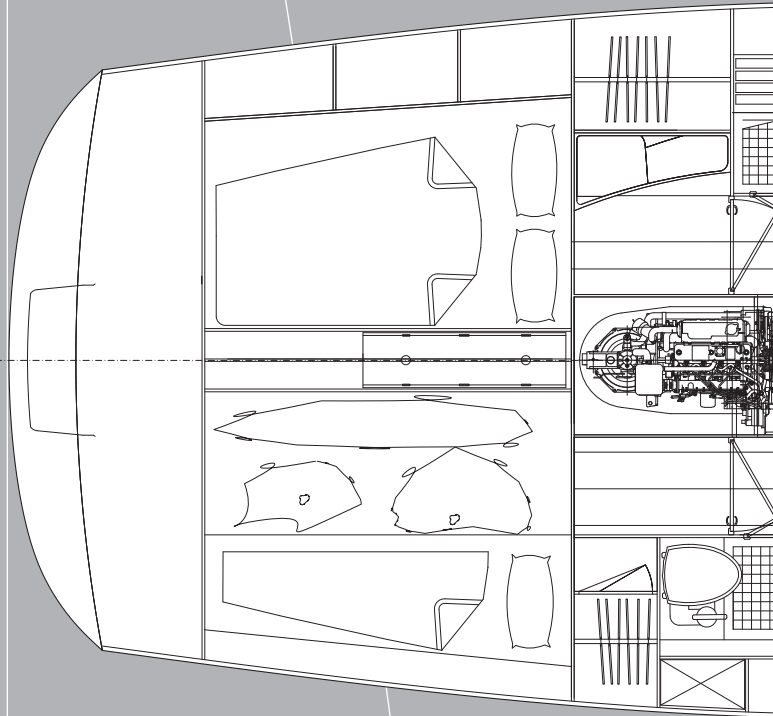

14

13

12

11

10

9

INTERIOR B

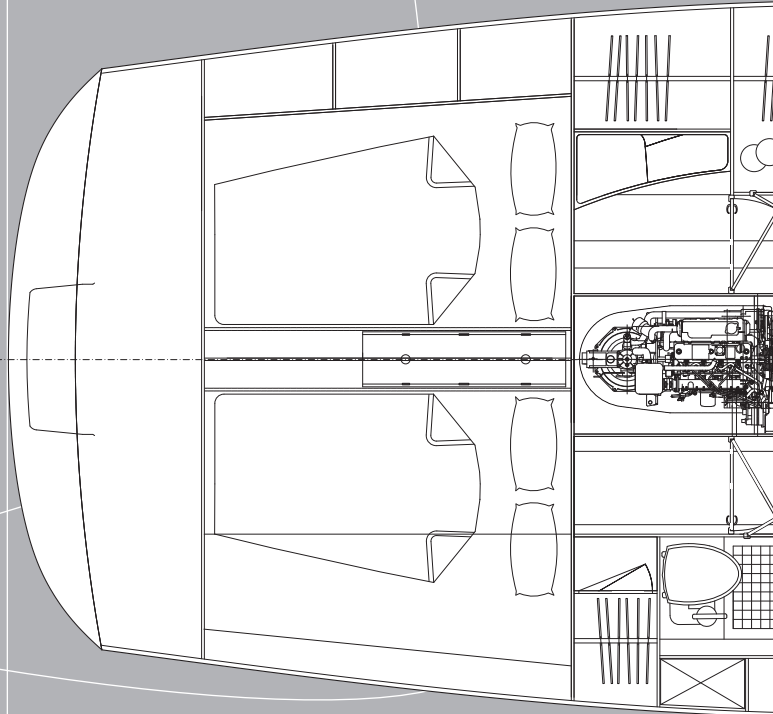

**LAYOUT A**

- ▶ Two cabin layout

**LAYOUT B**

- ▶ Three cabin layout

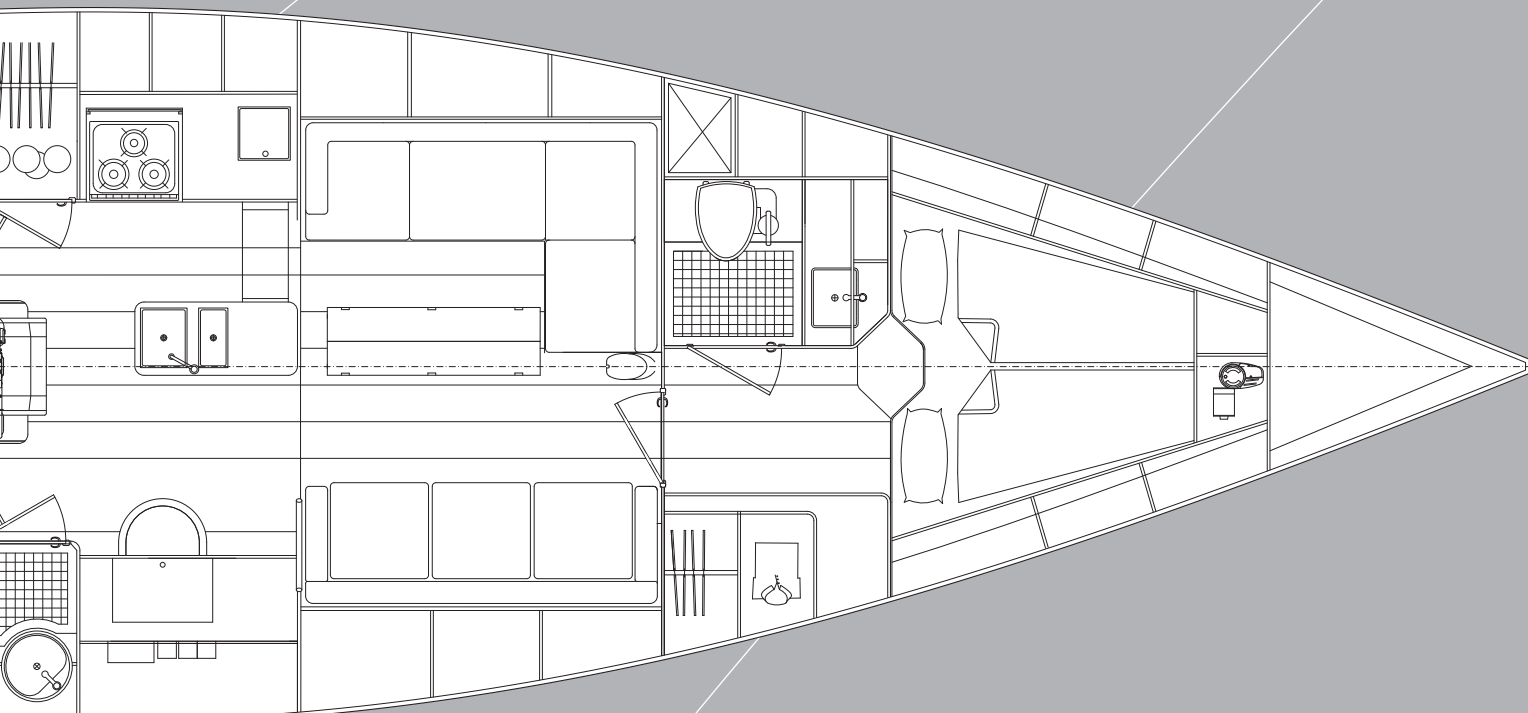
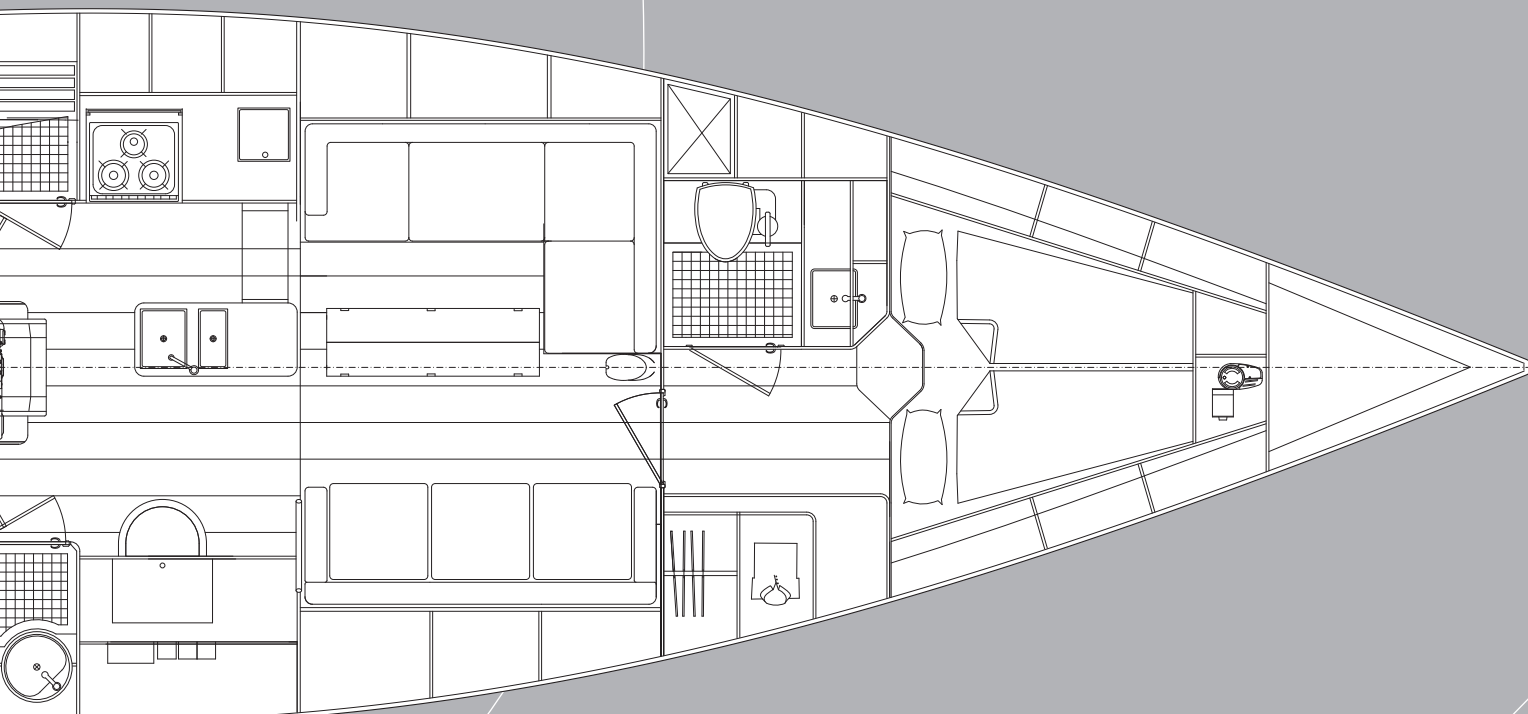

## SPECIFICATIONS CONTEST 40CS

|                  |                   |            |
|------------------|-------------------|------------|
| Length overall   | 12,50 m           | 41'0"      |
| Length waterline | 11,15 m           | 36'5"      |
| Maximum beam     | 3,91 m            | 12'8"      |
| Displacement     | 9,800 kg          | 29,750 lbs |
| Draft bulb keel  | 1,95 m            | 6'39"      |
| Mainsail         | 47 m <sup>2</sup> |            |
| Genoa            | 43 m <sup>2</sup> |            |
| Fuel tank        | 250 ltr           | 55 imp.gal |
| Water tank       | 400 ltr           | 88 imp.gal |

### VARIATION

- ▶ Two or three cabin layout

### DESIGNER'S COMMENT

The Contest 40CS will respond perfectly to those who are looking for a modern-rigged and fast, though stylish sailing yacht. It was a great challenge to work on a model in the CS range with an aft cabin and consequently sportier look. In my eyes, the design, performance and comfort are in perfect balance on this 40-footer.

Georg Nissen, DESIGNER

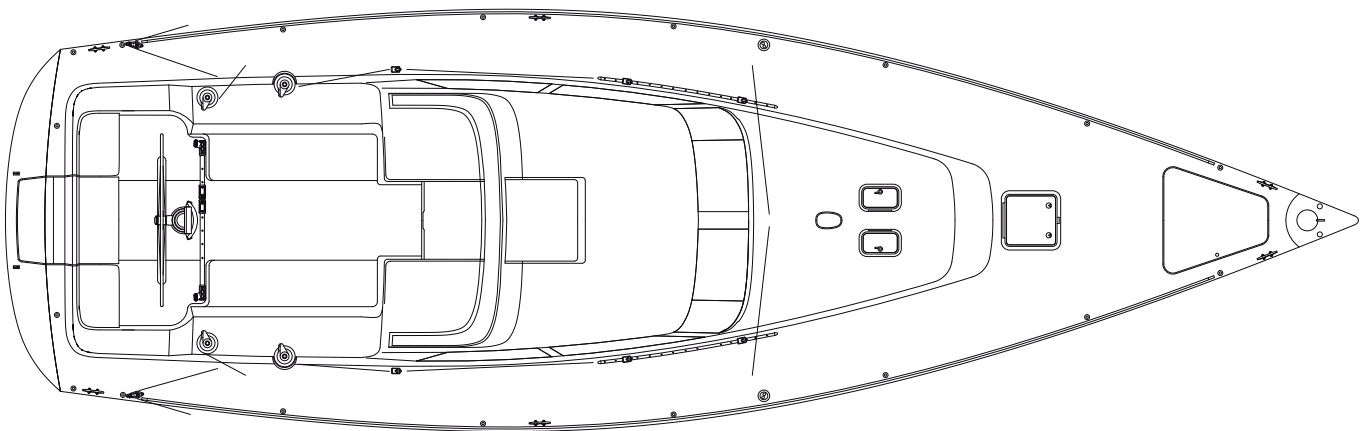



CONTEST YACHTS  
Overleek 5  
1671 GD Medemblik  
Holland

tel +31(0)227 543 644  
fax +31(0)227 543 648  
info@contestyachts.com  
www.contestyachts.com